

Operation of 3,000-Volt Locomotives On the Cleveland Union Terminals Electrification

BY F. H. CRATON*

Associate, A.I.E.E.

and

H. W. PINKERTON†

Non-member

Synopsis.—The operation of the 3,000-volt direct-current passenger locomotives on the Cleveland Union Terminals electrification has been studied after an initial period of service of more than two years. Twenty-two locomotives weighing 210 tons each are in service, normally handling passenger trains weighing 1,275 tons trailing over grades as high as 1.56 per cent.

During the two years over 1,000,000 miles of operation have been recorded, divided between about 410,000 miles per year for passenger service and 90,000 miles for switching. These figures indicate that the average performance in switching service is about two miles per hour, whereas the customary method of accounting credits switching locomotives with six miles per hour.

An analysis of the average time used for inspection and repairs shows an availability of 92 per cent. For the same period the utilization factor of 54 per cent is observed. The utilization factor will doubtless be improved with a resumption of normal traffic.

Data is given on energy consumption, both in road and in switch-

ing service, and curves are plotted showing the variation in energy consumption with different train weights. The all-day-average in coach-yard switching is found to be about 85 kwhr per hour per locomotive, including auxiliaries, or a net average of about 55 kwhr per hour. Interesting records of brush wear, data on replacement of hub liners, wear on pantograph strips and condition of commutator and motor bearings are produced.

The record of failures for the two-year period of operation shows twelve engine delays of three or more minutes. Six of these were classed as electrical failures, giving 170,000 locomotive miles per failure. There were no failures due to mechanical causes or hot bearings in journals, traction motors or auxiliaries.

In addition to the energy consumption curves, speed-time-current curves for the Twentieth Century Limited, a profile of the line, main and auxiliary circuits for the locomotive, and characteristic curves are given.

* * * * *

THE 3,000-volt direct-current electrification of the Cleveland Union Terminals Company has been in complete operation since June 29, 1930. The facility which attended the rapid transition from steam to electric operation with the opening of the new Union Station and the unusually successful performance of the equipment reflected the careful planning of the management. Not only the initial period of operation was comparatively trouble-free, but also the two years subsequently have witnessed successful performance. A few of the inevitable minor difficulties have come up and been corrected, but no trouble of fundamental importance has been encountered. It is the purpose of this paper to review briefly the design and characteristics of the locomotives selected for this work, and then to deal with the operation of these locomotives over the first two-year period of their service.

PHYSICAL CHARACTERISTICS

Fig. 1 shows the profile of the electrified line from Collinwood to Linndale, involving about 17 route miles and 56 miles of track. New York Central passenger trains are electrically operated between Collinwood and Linndale, Big Four trains between the Union Station and Linndale, and Nickel Plate trains for about two miles on each side of the Union Station. Power is fed to the 3,000-volt d-c overhead contact line by two supervisory controlled substations of 18,000 kw total capacity.

*General Electric Co., Erie, Pa.

†Cleveland Union Terminals Co., Cleveland, Ohio.

Presented at the Winter Convention of the A.I.E.E., New York, N. Y., January 23-27, 1933.

LOCOMOTIVES

The same locomotives are used in both switching and road service and hence all 22 units are identical. The conditions to be fulfilled by the locomotives very definitely fixed their general design. The necessity for starting a 1,275 ton train on the 1.56 per cent (1.63 per cent compensated for curvature) grade demanded a driver weight of about 300,000 lb. Negotiation of a 262-ft curve with train attached, called for a flexible

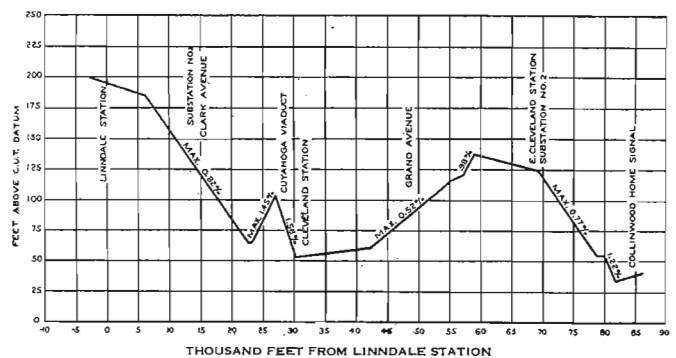

FIG 1—PROFILE

running gear. The schedule requirements were covered by a typical run with a 1,275-ton train calling for a running time between Collinwood and Linndale, exclusive of stops, of 33 minutes westward and 30 minutes eastward. These requirements plus wheel-loading limitations and high-speed operation resulted in the design covered by Table I being adopted. The main and auxiliary circuits are shown in Fig. 2 and the characteristics of the locomotive are given in Fig. 3

TABLE I—LOCOMOTIVE DATA

Weights	Pounds
Total working order.....	419,000
On drivers.....	312,000
Per driving axle—average.....	52,000
Guiding.....	107,000
Per guiding axle—average.....	26,750
Total—light.....	410,000
Cab, platform and running gear.....	265,780
Traction motors (including gearing).....	72,880
Other equipment.....	71,340

Traction Motors	
Number and type.....	6 GE-278-C
Rated voltage.....	1,500/3,000
Method of drive.....	Twin gear—cushion type
Gear ratio.....	74/27 = 2.741
Ventilation.....	Forced

Locomotive Ratings—3,000 Volts	One Hour—Blown		Continuous—Blown	
	Full field (FS-1)	Full field (FS-1)	Rd. field (FS-3)	Rd. field (FS-3)
120° C rise by res.				
Tractive effort—lb.....	30,600	25,500	19,200	
Coef. adhesion—%.....	9.81	8.18	6.15	
Speed—mph.....	37	38.5	51.5	
Horsepower.....	3,030	2,635	2,635	
Amperes.....	825	720	720	
Tractive effort at 25% adhesion—78,000 lb				
Maximum speed—70 mph				

Nomenclature..... 2-C+C-2 419/312 6 GE-278-C—3,000 volts
 Control.... Type PCL (M.U.) 3 speeds full field 6 speeds reduced field
 Current collector..... 2 pantographs—sliding contact type
 Braking..... Air
 Train heating equipment..... Automatic oil fired steam boiler

realized. The operation of the Cleveland locomotives is based on this fact. Examination of the profile, Fig. 1, shows that both eastward and westward runs include several heavy grade sections. To handle the heavier trains on these portions of the line demands tractive efforts greatly in excess of the locomotive continuous tractive effort rating. In this respect the westbound run is the more severe.

The train covered by the Terminals Company Specifications consisted of 1,275 tons of steel passenger cars to be hauled between Collinwood and Linndale, with a ten minute stop at the Terminal, both eastbound and westbound, a two-minute stop at East Cleveland, both eastbound and westbound, and a stop of no duration on the three-degree and five-degree curves on Cuyahoga Viaduct, westbound only, with ten minute layovers at Collinwood and Linndale. Maximum running time exclusive of stops was specified as 33 minutes westbound and 30 minutes eastbound with an average line voltage of 2,700 and braking at 1.0 mphs.

In handling the specified train of 1,275 tons, or fifteen 85-ton cars, no restriction is placed on the use of intermediate (FS-2) or minimum (FS-3) traction motor field strength. By limiting the operation to intermediate field between Collinwood and the Terminal, and full field from the Terminal to Linndale, a train of nineteen 85-ton cars may be handled on the westward run with stops at East Cleveland and the Terminal, but omitting the Viaduct stop.

Fig. 4 gives an idea of train operation through the electric zone, being based on speed-current-time data

LOCOMOTIVE OPERATION—ROAD SERVICE

Operation of electric passenger locomotives over a 17-mile line must involve use of the short time capacity of the electrical equipment if its full utility is to be

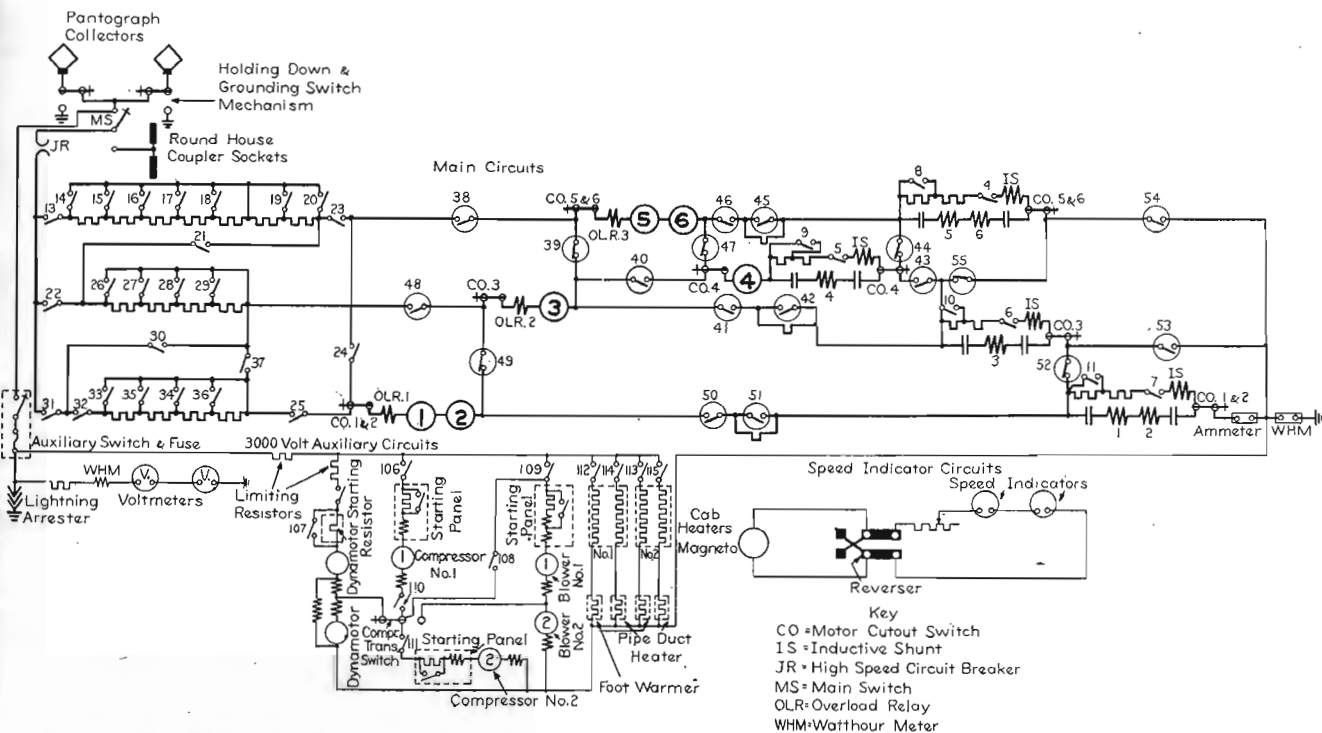

FIG. 2—MAIN AND AUXILIARY CIRCUITS FOR CLASS 2 - C + C - 2 - 300/408 - 6GE278C, 3,000-VOLT PASSENGER LOCOMOTIVE, SCHEMATIC CONNECTION DIAGRAM, FOR CLEVELAND UNION TERMINALS CO., CLEVELAND, OHIO

taken on one section of "The 20th Century Limited" running westward from Collinwood to Linndale with one stop (at the Terminal). The train consisted of one electric locomotive hauling thirteen cars averaging 84.5 tons each, giving a trailing tonnage of 1,100. The specific conditions of this run are quite different from the contract requirements.

LOCOMOTIVE OPERATION—SWITCHING SERVICE

Two locomotives are used in coach yard switching and three in regular passenger switching in the Station. Part of the coach yard trackage is on the Viaduct grade which makes it necessary to have the same weight on drivers for the switchers as for the road engines. To give added flexibility to the Terminal operation, it was thought desirable to have switching locomotives suitable for road service also. Hence all locomotives are

OPERATING AND MAINTENANCE DATA

In the following discussion of the record of these locomotives to date, it should be understood that due allowance must be made for the limited time in service upon which the records are based. Twenty-two locomotives were purchased and went into complete revenue operation at the time of the initial changeover. At present, (October 12, 1932) three locomotives are in storage due to decline in traffic, the remaining nineteen being in regular service as heretofore. The Terminals Company has kept a very complete service and maintenance record on all locomotives since the beginning of operation, and the following data are based on this record.

Mileage. The total mileage for all locomotives for the first two years of operation was slightly over 1,000,000. For the year 1931, the following locomotive mileages were recorded:

Passenger revenue miles.....	412,410
Switching miles in station and coach yard.....	89,428
<hr/>	
Total revenue miles.....	501,838
Work train service miles.....	650
<hr/>	
Total locomotive miles.....	502,488

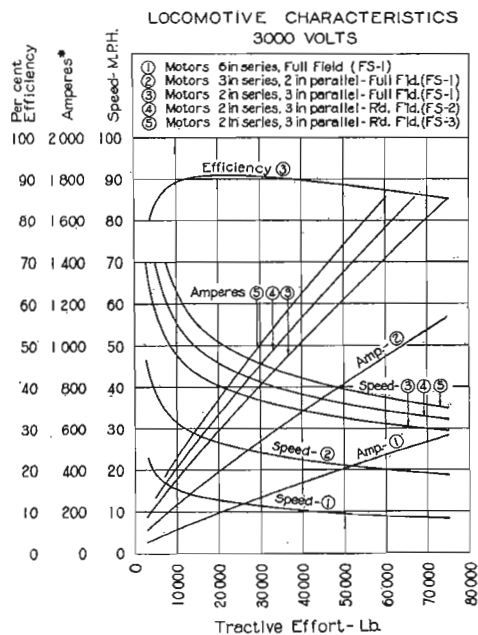

FIG. 3—LOCOMOTIVE CHARACTERISTIC CURVES

identical and therefore available for any class of work on the Terminal property. The use of road locomotives in switching service has proved entirely practicable. The highly flexible running gear helps in this respect, although the guiding truck centering device has high initial restraint, this decreases rapidly beyond about 1½-in. displacement of the bolster, thus keeping the guiding wheel flange wear to a minimum, even in the switching work where comparatively sharp curves are encountered. The locomotive has a three-speed control which gives 1/3 voltage per traction motor armature in the low-speed running connection. This permits switching movements to be made with a minimum of rheostatic losses consistent with the use of high-speed gearing.

The switching mileage in the above tabulation is actual odometer miles, and is reported as such because of accounting requirements of the Terminals Company. It is usual practise, however, to report switching mileage at 6 mph, which would raise this item from 89,428 to 262,800 miles. In other words, the actual switching mileage in this case is equivalent to only 2.04 mph. Based on 6 mph for switching, the total revenue miles is 675,860 or 30,700 revenue miles per locomotive per year, as compared with about 22,800 revenue miles per locomotive per year based on odometer switching miles. The annual unit mileage will increase with an upturn in traffic. During the early months of operation in 1930, the locomotive mileage was at the rate of about 30,000 per unit per year, including switching miles as measured by odometer.

Availability. There are no actual availability data but a reasonably close estimate can be made. There is an average of two locomotives in the shop for regular monthly inspection and for repairs. These are actually under repair or inspection 48 hours each per week, making a total of 96 hours. In addition, each locomotive in service requires a daily inspection, followed by minor repairs, if required, which averages about 1½ hours per locomotive, or 189 hours per week for an average of 18 locomotives dispatched each day. This makes 96 plus 189, or 285 total actual out-of-service hours per week for inspection and maintenance. Based on this, the availability is 92 per cent.

Utilization Factor. Based on the actual hours for which crews were paid, the locomotives were in service 104,555 hours during the year 1931. Of this total, 43,800 hours were operated in switching service and the remaining 60,755 hours in road service. The total locomotive hours for 1931 being $22 \times 365 \times 24 = 192,720$, the utilization factor was 54.2 per cent. Al-

Brush Wear. From present available data, traction motor brush life will vary between a minimum of 50,000 miles and a maximum of 100,000. As so many of the original brushes are still in service, definite figures cannot be given yet.

Hub Liner Replacement. In 1931, 110 hub liners were replaced. About 75 per cent of these were on the drivers and 25 per cent on the guiding wheels. No mileage records have been set up for hub liner replacement.

Pantograph Strip Wear. In operating trains in 1931, both pantographs were used, making a total of eight strips (copper) in use simultaneously on each locomotive. Average mileage per replacement was about 8,000.

Traction Motor Overhaul. Owing to the limited period of operation so far, the traction motor overhauling schedule has not been started. Commutator wear is negligible to date. Wear of axle and armature linings to date has been almost negligible. These bearings are

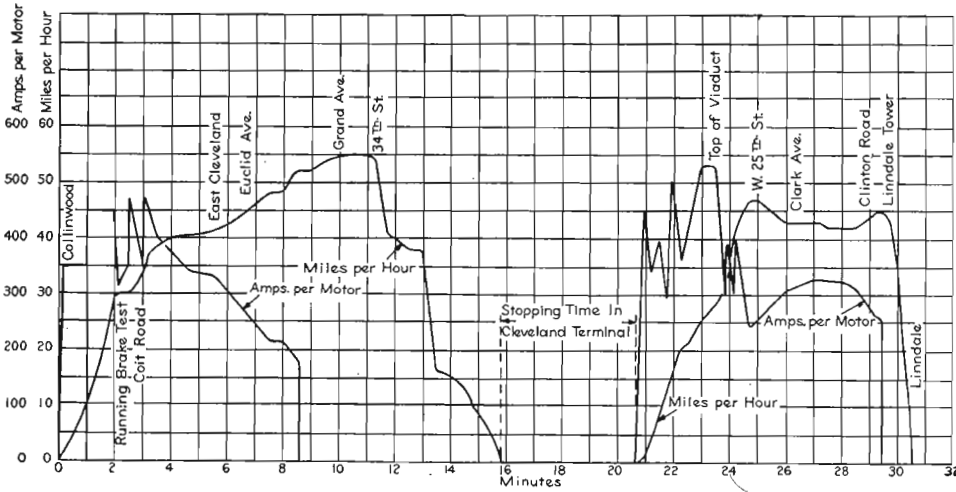

FIG. 4—SPEED-CURRENT-TIME CURVES FOR "THE 20TH CENTURY LIMITED" FROM COLLINWOOD TO LINNDALE, DEC. 2, 1931. TRAILING TONS, 1,100. CLEVELAND UNION TERMINALS ELECTRIFICATION

though this is a very good showing, the utilization will be markedly improved with more traffic.

Energy Consumption. The results of energy consumption tests in road movements between Linndale and Collinwood are plotted in Fig. 5. The test trains consisted of cars averaging 82 tons each. The values given are average watthours per trailing ton mile for the complete run from Collinwood to Linndale and vice versa, with stops at E. Cleveland and the Terminal in both cases. Curves are based on maximum schedule speed consistent with observance of all speed restrictions.

A number of observations of energy consumption in switching service has been made. It has been found that for the two locomotives in the coach-yard switching, where the work is almost continuous, the all day average is about 85 kwhr per hour per locomotive, including auxiliaries. Subtracting auxiliary power gives a net all day average of about 55 kwhr per hour to the traction motor circuits for this work. In the regular train switching in the station, the all day average is about 65 kwhr per hour including auxiliaries, three locomotives being assigned to this. However, this work is of an intermittent nature, which accounts for the lower power consumption. The all day average to the traction power circuits in this service is about 40 kwhr per hour although the maximum hour is comparable with the coach yard average work. These figures compare with 50 to 60 kwhr per hour to the traction motor circuits in heavy freight switching as determined by tests on the New York Central and the Delaware, Lackawanna & Western.

of the constant oil level type, which maintain an approximately constant depth of oil in the waste chamber until the supply in the large capacity reservoir adjacent to the bearing is used up.

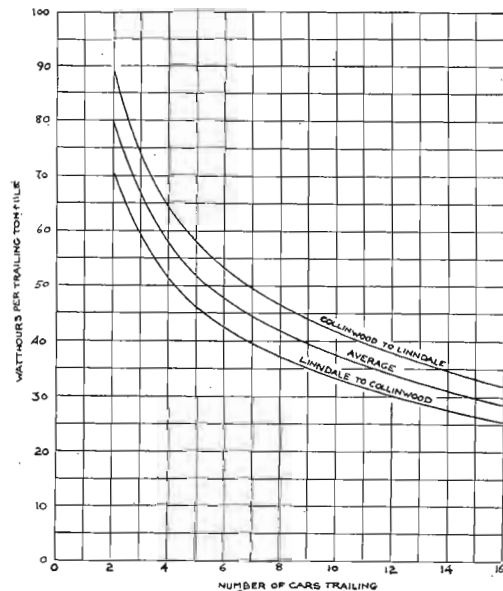

FIG. 5—ENERGY CONSUMPTION CURVES

Failures. In the first two-year period of operation, there were twelve engine failures causing delays of three or more minutes. Six of these were classed as man failures, due largely to the inexperience of the crews in handling the new equipment. The other six

were classed as electrical failures, giving about 170,000 locomotive miles per electrical failure. There were no failures due to mechanical causes nor were there any cases of hot bearings in either journals, traction motors, or auxiliaries.

In the Winter of 1931-1932, unforeseen trouble was experienced due to unseasonable lightning storms, which on four occasions caused minor damage to the electrical circuits while the lightning arresters were out of service.

It is proposed to remedy this condition by operating arresters (aluminum cell type) throughout the Winter and provide means for heating them to prevent freezing of electrolyte.

ACKNOWLEDGMENT

The authors wish to thank Mr. H. D. Jouett of

The Cleveland Union Terminals Company for making available the data upon which this paper is based, as well as for valuable criticism of the original manuscript. Thanks are extended also to Mr. H. A. Currie of the New York Central Railroad for much helpful comment.

Bibliography

"Cleveland Union Terminals," Lacher, Walter S., *Railway Age*, June 28, 1930.

"Design for a Passenger Locomotive for The Cleveland Union Terminals Company," Cain, B. S., *General Electric Review*, March 1931.

"Motor Generators Supply Power for Cleveland Union Terminals Electrification," McDonald, G. R., *Railway Electrical Engineer*, October 1930.

Design of Catenary System for Cleveland Union Terminal, Clement, N. F. and Richards, E. E., *TRANS. A.I.E.E.*, **50**, June 1931.